



Models - 8670 & 8651 series No/Bill Acceptor
8671 & 8652 Series with Bill Acceptors

Page 2	Product Information
Page 3	Specifications
Page 4	Important Safety Instructions
Page 5	Product Dimensions
Page 6-11	Installation
Page 12	Timer Set-Up
Page 13	Operating Instructions & Maintenance
Page 13-14	Troubleshooting
Page 15-20	Parts List
Page 21	Wiring Diagram



PRODUCT INFORMATION

Please take a moment to fill out the information below in order to aid us with any future sales or service inquiries. Model number and serial number information can be found on the serial tag located inside the control box and/or on the lower exterior of the can. Key number can be found on the tag that comes attached to the keys. There may be more than one key number depending on unit.

Please keep this information with your records.

MODEL#: _____

SERIAL#: _____

KEY NUMBER(S): _____

DATE PURCHASED: _____

DISTRIBUTOR: _____

**J.E. Adams Industries
1025 63rd Ave. S.W.
Cedar Rapids, IA 52404
1-800-553-8861
www.jeadams.com**

Specifications

<u>Unit specifications:</u>	8670, 8671, 8651 & 8652 Series
Voltage:	120vac, 60hz
Amperage:	(1) 15 amp service is required (twin cylinder compressors or compressor-less)*
Compressors:	¾ HP, twin cylinder models
Water Solenoid:	120vac, 60hz
Timer:	SSAC is standard, others timers available upon request
Weight:	77 lbs. twin cylinder models, no packaging

Twin cylinder



DUTY CYCLE: 4 minutes on, 4 minutes off.

NOTE: “UNIT INTENDED FOR COMMERCIAL USE ONLY”

IMPORTANT SAFETY INSTRUCTIONS

When using an electrical appliance, basic precautions should always be followed, including the following:

READ ALL INSTRUCTIONS BEFORE USING (THIS APPLIANCE)

WARNING – To reduce the risk of fire, electric shock, or injury:

- Use only as described in manual. Use only manufactures recommended attachments.
- Do not allow to be used as a toy. Close attention is necessary when used by or near children.
- Do not put any object into openings. Do not use with any opening blocked; keep free of dirt and anything that may reduce flow.
- Keep hair, loose clothing, fingers, and all parts of body away from openings and moving parts.
- Do not use near flammable or combustible liquids, such as gasoline, or use in areas where they may be present.
- Do not use near anything that is burning or smoking, such as cigarettes, matches, or hot ashes.
- Products such as "Fix-A-Flat" are highly combustible and cannot be used in conjunction with air machine!



SAVE THESE INSTRUCTIONS



- **Installation Instructions:**
- Determine location to mount unit (“**DANGER**” “**THIS EQUIPMENT INCORPORATES PARTS SUCH AS SWITCHES, MOTORS, OR THE LIKE THAT TEND TO PRODUCE ARCS OR SPARKS THAT CAN CAUSE AN EXPLOSION. WHEN LOCATED IN GASOLINE-DISPENSING AND SERVICE STATIONS INSTALL AND USE AT LEAST 20 FEET (6 M) HORIZONTALLY FROM THE EXTERIOR ENCLOSURE OF ANY DISPENSING PUMP AND AT LEAST 18 INCHES (450 MM) ABOVE A DRIVEWAY OR GROUND LEVEL.**”
- Run electrical service to that location.
- **Grounding Instructions:** This appliance must be connected to a grounded metal, permanent wiring system; or an equipment-grounding conductor must be run with the circuit conductors and connected to the equipment-grounding terminal or lead on the appliance.
- All local and national electric codes must be followed for installation and use.
- Licensed electricians are recommended for installation.
- Licensed plumbers are recommended for installation (water machines).

PRODUCT DIMENSIONS

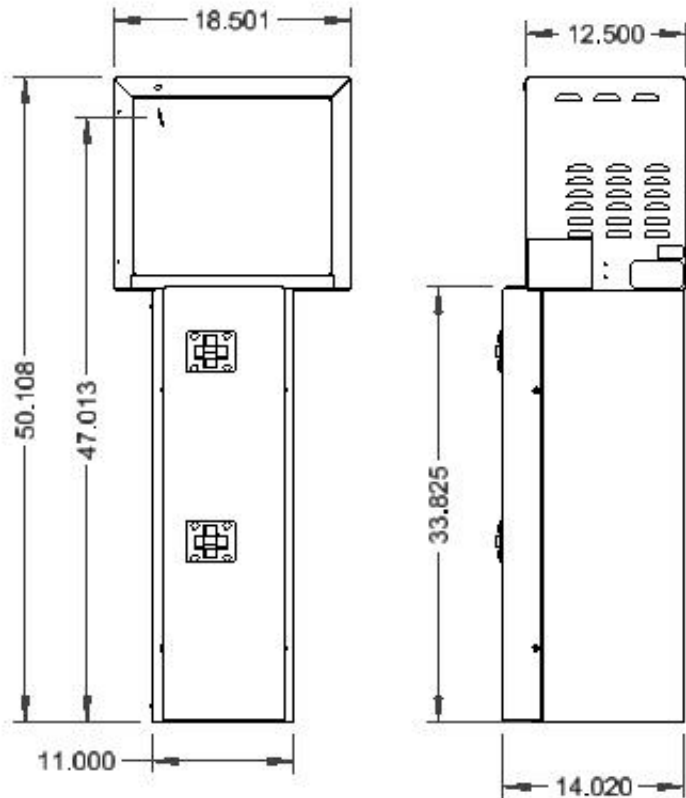

AIR/WATER MACHINE
WITH 6025 BASE.

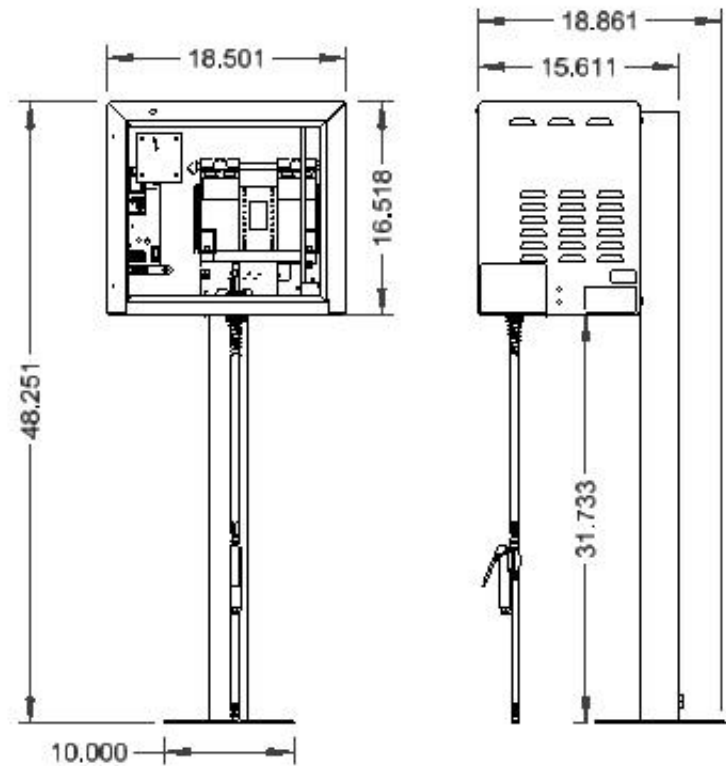

AIR MACHINE
WITH 8819 BASE.

For compressor-less units, air supply to be routed by customer to solenoid inside air machine

Wall mounting:

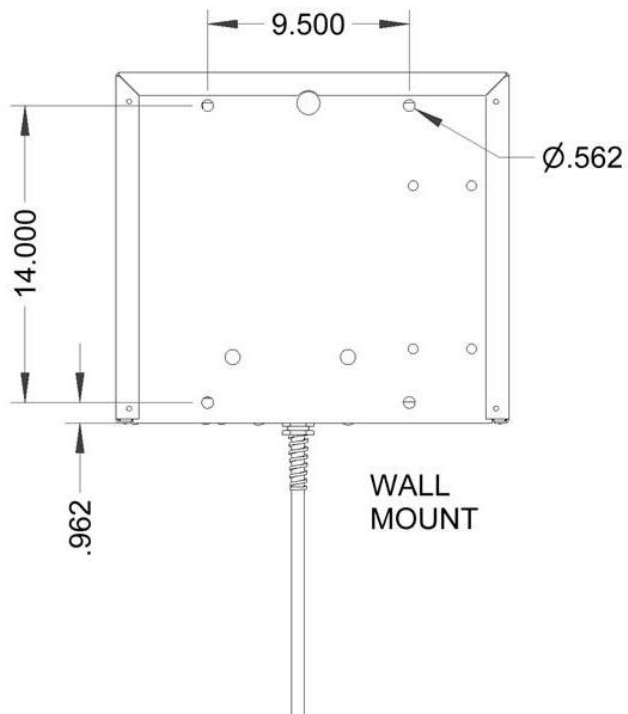

WALL MOUNTING PATTERN, REAR VIEW:

Use minimum 3/8" diameter bolt and drill/anchor at least 4" into block or concrete.

Drill holes according to rear of cabinet 9.5" x 14" bolt pattern.

After drilling holes in concrete wall for mounting, open cabinet door and lift/align cabinet to wall and fasten with customer supplied hardware.

Use two people!!

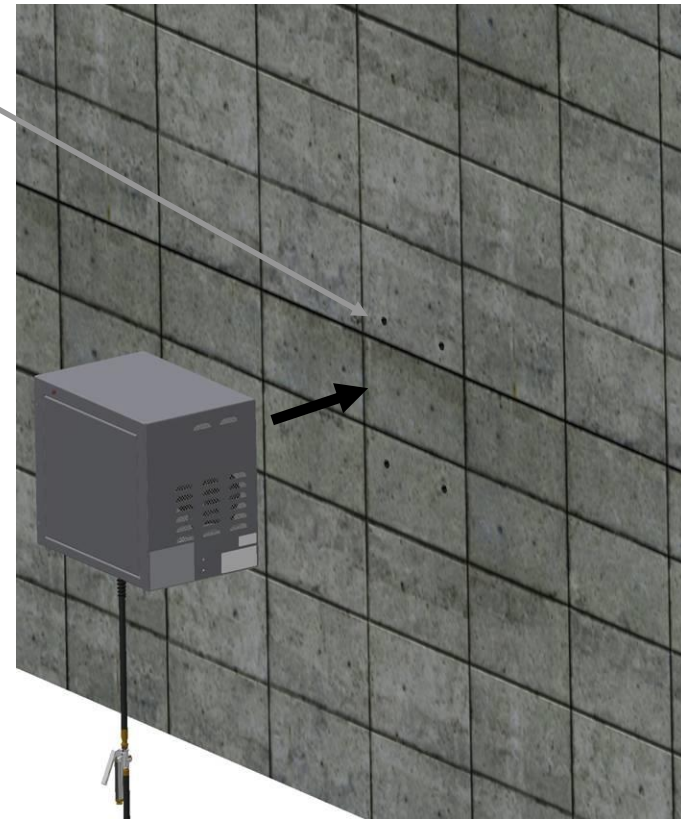

8819 pedestal mounting:

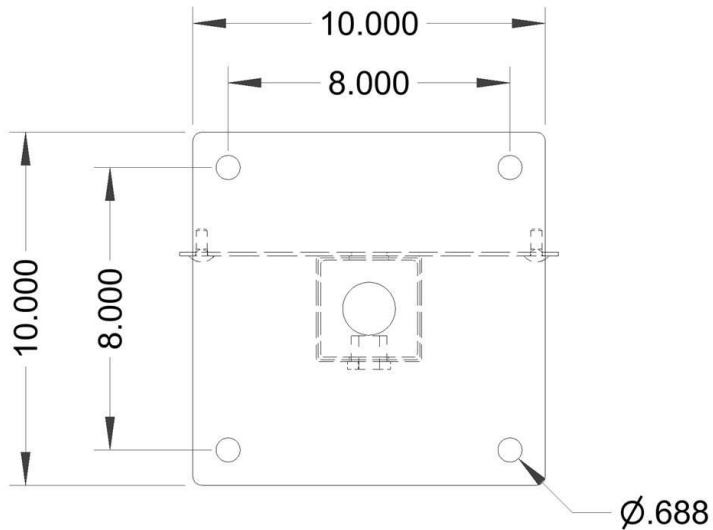

PEDESTAL MOUNTING PATTERN, BOTTOM VIEW:

Use minimum 3/8" diameter stud and
drill/anchor at least 4" into concrete.

After mounting pedestal to concrete,
open cabinet door and lift/align cabinet to
pedestal with nuts/washers to carriage
bolts on pedestal mounting plate.

Use two people!!



6025/6026 reel base mounting:

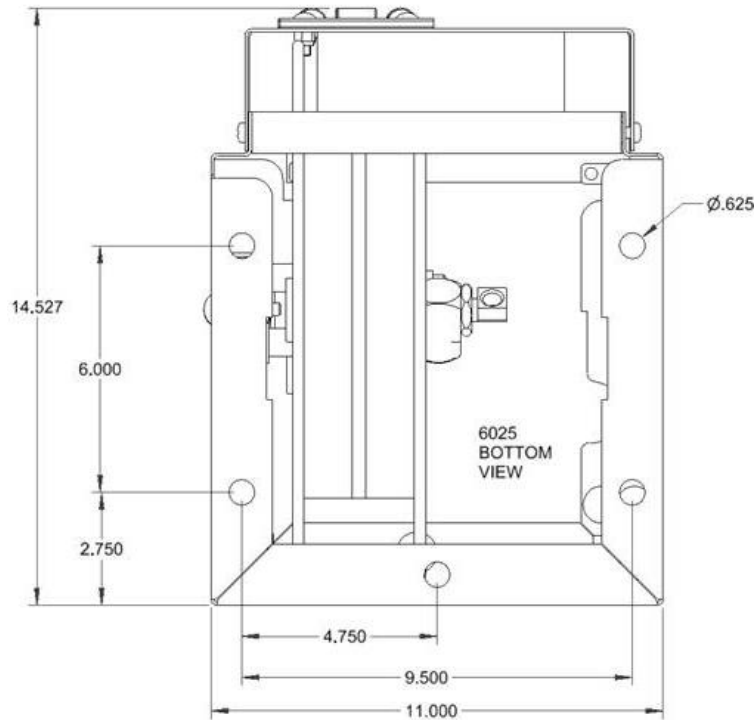

REEL BASE MOUNTING PATTERN, BOTTOM VIEW:

Use minimum 3/8" diameter stud and drill/anchor at least 4" into concrete.

After mounting reel base to concrete, open cabinet door and set air cabinet onto reel base. Fasten cabinet with bolts provided to reel base.

Use two people!!



Install the 8545-4 lines to the air compressor and *water solenoid* inside the air cabinet and then to the hose reels in the base.

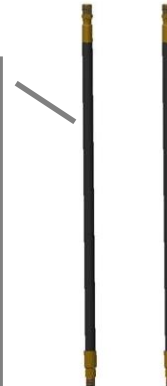

*Air/ Water machines only

8670 cabinet:

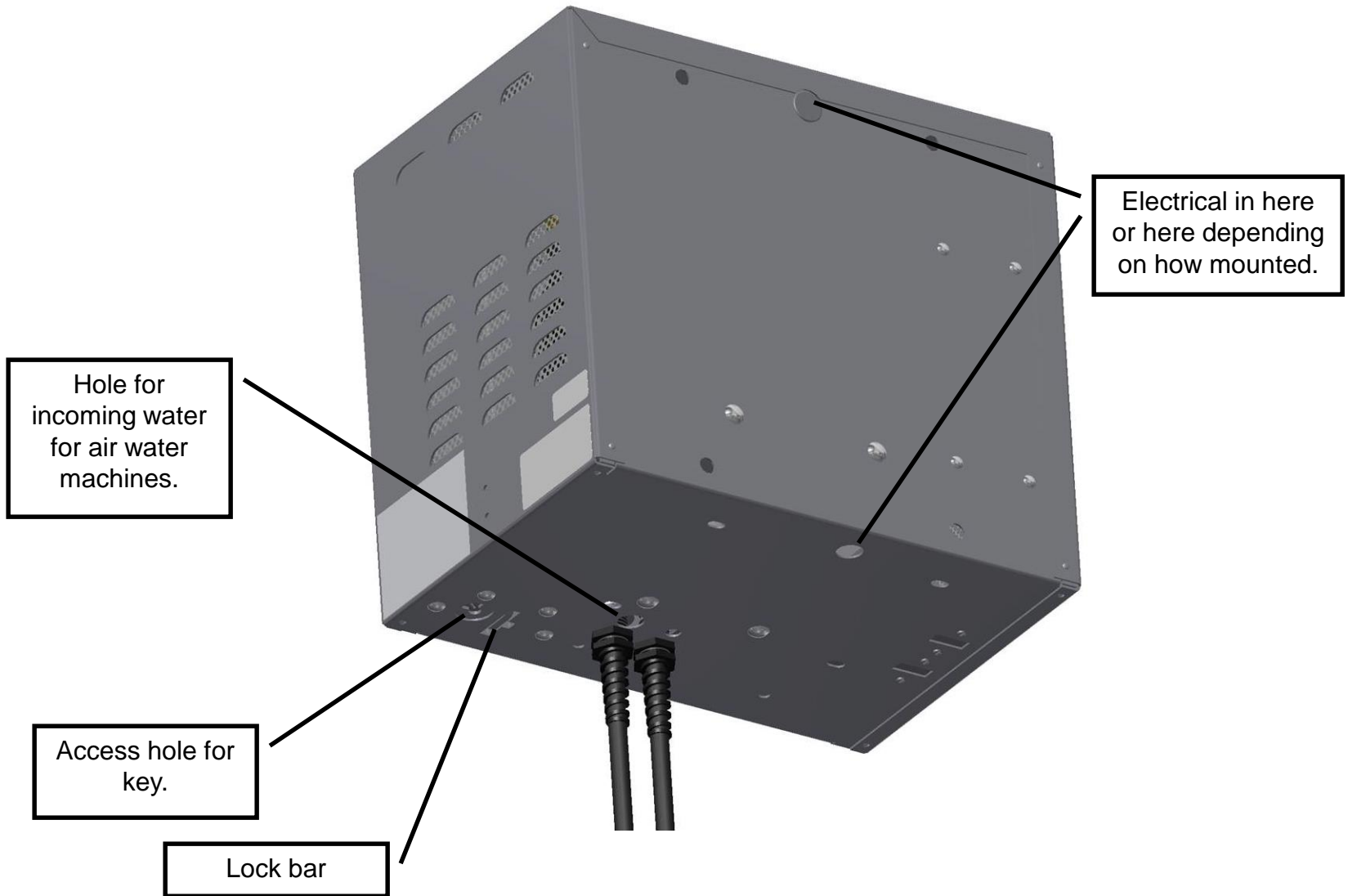

Customer supplied compressor:

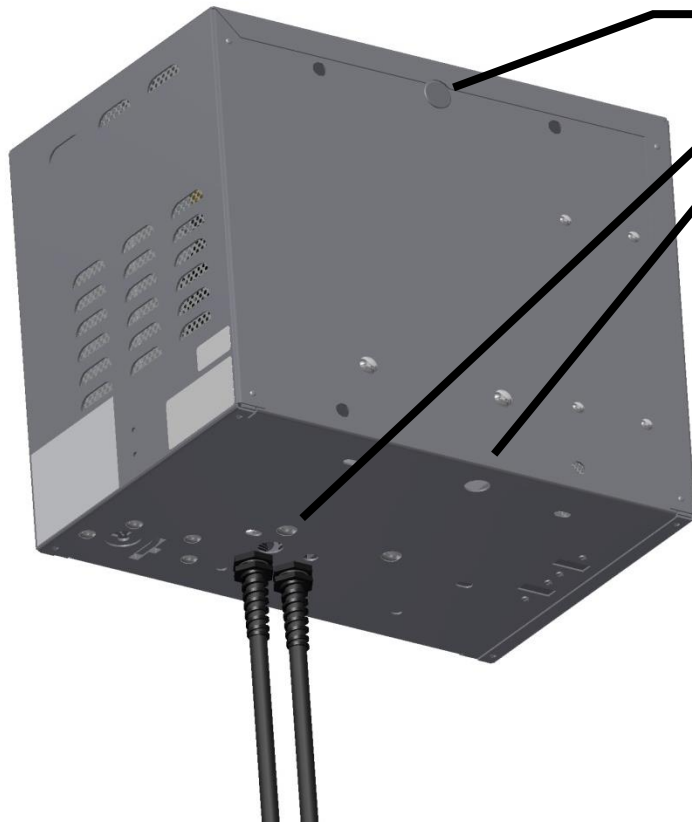

Incoming electrical, air line, or water supply can enter cabinet in several locations depending on installation method.

Incoming air or water line is connected to the brass solenoid (1/4" NPT) which is activated when the timer is sending power.



Electrical:

Open door to air machine
to access terminal strip.

**NOTE: AIR
MACHINE
SHOULD BE
INSTALLED
PER LOCAL
ELECTRICAL
CODES BY
QUALIFIED
ELECTRICIAN.**

Consult electrical
diagram on last
page of manual
for specifics.
Connect 120V
white "neutral"
here.

Consult electrical
diagram on last
page of manual for
specifics. Connect 120V
black "hot" here.

Consult electrical
diagram on last
page of manual
for specifics.
Connect green
"ground" here.

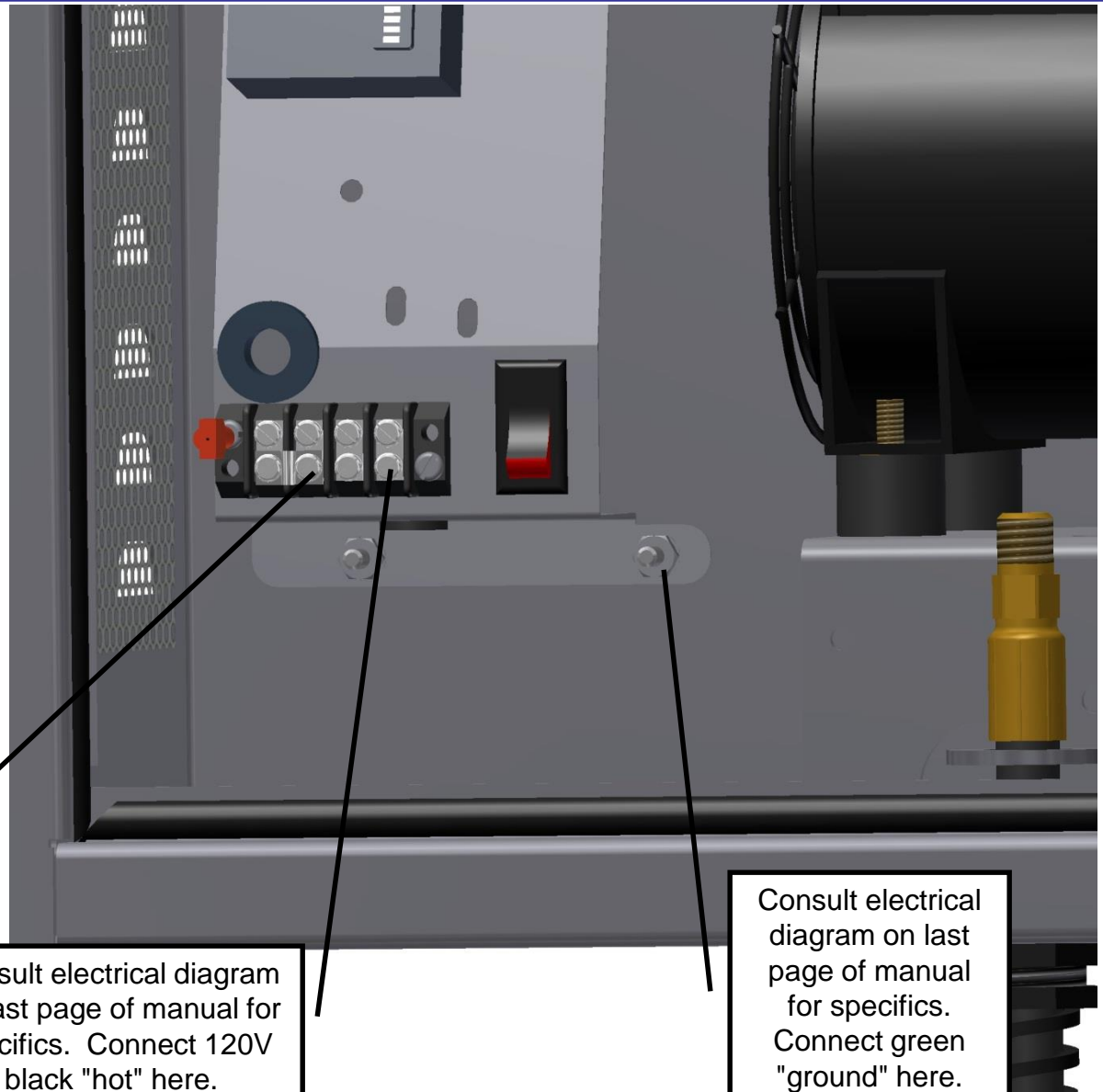

Programming:

The below timer pictured is the standard SSAC model that allows the end user to select the "coins to start" and the "total time" by settings series of dip switches. The number of "coins to start" dip switch is how many quarters are needed to make the machine come on. In the below example, the "one coin" dip is selected which makes the unit come on with one coin. The "total time" will then need to be set, but a good rule of thumb would be 4 minutes which requires dip switches 3.2 and .8 to be set to on. This scenario means 1 quarter will provide 4 minutes of vacuum time. The total time can always be changed by adding or subtracting time. If the operator would later decide to increase the cost of the unit to "2" quarters, the 2 dip switch would need to be in the on position (all others off) and the time dip switches would still be 3.2 and .8 dips selected for 4 minutes. Timer is non accumulating so "coins to start" setting is just to make the machine come on time and "time" is total time regardless of coins to start.

Time in minutes dip switch settings:

0.2	=	12 seconds
0.4	=	24 seconds
0.8	=	48 seconds
1.6	=	96 seconds
3.2	=	192 seconds
6.4	=	384 seconds

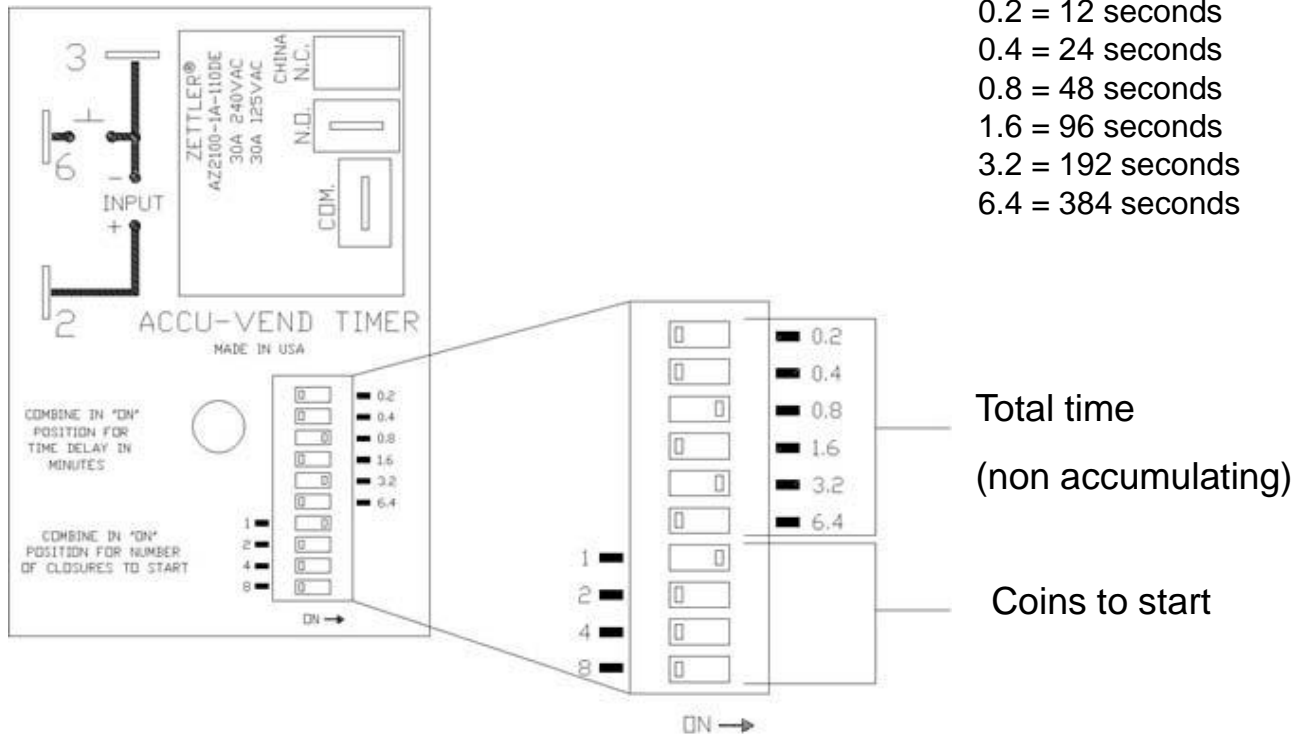

Machine Operating Instructions:

- 1) Read safety instructions on previous pages.
- 2) Insert coins (or bills) to start.
- 3) Compressor will start.
- 4) Apply chuck to tire valve stem and fill to desired pressure. NOTE: For best results, remove valve stem covers on all tires before depositing money.
- 5) Hang hose up when finished.

Maintenance:

- **All servicing of machine should be conducted by an authorized service representative!**
- Periodically inspect hose, chuck, and chuck washer for wear or fatigue.
- Every month remove filter from compressor and clean.
- Periodically inspect electrical wires and connections for wear or fatigue.
- Clean canister with a stainless steel cleaner as needed.
- Decals can be cleaned with mild soap and water.
- Replacement parts can be ordered through JE Adams or your nearest dealer.

WHEN PERFORMING MAINTENANCE OR TROUBLE-SHOOTING, TURN POWER OFF! QUALIFIED PERSONNEL ONLY!



TROUBLESHOOTING:

ALWAYS DISCONNECT POWER BEFORE TROUBLESHOOTING!!

Problem	Possible cause	Solution
Unit is not powered.	Breaker inside fuse panel is not in the on position.	Turn breaker on.
	No power to machine.	Check incoming power line voltage.
	Machine power switch is not on.	Remove dome and flip switch.
	Loose connection.	Check incoming power connection.

Unit runs but will not inflate tire.	Air is leaking from unit somewhere.	Turn power off to unit, apply chuck to air source with at least 30lbs of pressure and listen carefully for leaks inside cabinet or air hose. Replace faulty component if leaking.
	If no system leaks, is compressor putting out enough pressure?	If compressor cannot force air into tire, the compressor may have exceeded its life span and need rebuilt (about 1000 hours).
	Chuck washer is worn out?	Replace rubber washer inside chuck with JE Adams PN 8533-3CW.
	Temperature is below freezing and condensation off compressor has froze in air hose.	Remove air hose and chuck and bring into warm area to thaw.
Unit keeps tripping breaker from incoming power source	Wrong size breaker or other components running on same circuit.	Install correct breaker for compressor and make sure line is a dedicated power source.
	Compressor or timer might be shorted out?	Isolate problem component and replace if necessary.
Unit will not start	Possible component failure	Check key components to isolate failure:
		Timer: Verify proper input voltage. Activate timer. If no output voltage is present when timer should be active, replace timer.
		Coin mech: If using a mechanical coin mech, remove the wires leading to the timer from the coin mech and tap them together one time for each coin necessary to start the timer. If machine starts, replace the coin mech.
Unit will not dispense water (water machines only).	Is source water turned on and not frozen?	Turn on water to system and make sure temperature is above 32 deg.
	Is water solenoid getting power from timer?	If getting power from timer, replace solenoid.

PART NO. **8670-2WGA**

BILL OF MATERIALS			
ITEM	PART NUMBER	DESCRIPTION	QTY
35	8754	DECAL, DANGER, TRI-LING	1
36	8773-3	AIR MACHINE COIN BOX	1
37	9862-2A	ASSEMBLY, GAST COMPRESSOR WITH WATER SOLENOID	1
38	S8670 SERIES SSAC	WIRING DIAGRAM	X

BILL OF MATERIALS			
ITEM	PART NUMBER	DESCRIPTION	QTY
1	10011-3W	DOOR WELDMENT, AIR MACHINE	1
2	1079-3	GASKET, RUBBER SEAL (DOOR)	60"
3	5600D2	5/16-18 x .75 CARR BOLT	2
4	5601D4	1/4-20 x 3/4 HHCS-SS	2
5	5601D8	1/4-20 x 3/8 HHCS-ZINC PLATED	5
6	5603D2	1/4 Std NC Nylock Nut	2
7	5606D21	WASHER, FLAT, 3/4 SAE, ID 13/16	2
8	5611D2	NUT, 10-24 UNC KEPP- ZINC	4
9	5684D2	1/2" DIA. HOSE CLAMP	2
10	5900D3	TERM, F SPADE, 1/4, 12-10 AWG, INS.	1
11	6408	CARDBOARD INSERT	2
12	6409	CARDBOARD BOX	1
13	8081	CABLE TIE MOUNTS	4
14	8084	CABLE TIE, NYLON 5-3/4	11
15	8124B001	COIN ACCEPTOR, IMONEX	1
16	8155A	LOCK ASSY-W/MEDECO CAM LOCK	1
17	8157	NUT, #6-32 KEPP NUT STAINLESS	4
18	8180	WARNING, WIRE TEMP RATING	1
19	8183	DECAL, "DISCONNECT POWER"	1
20	8431-1AKIT	DECAL KIT, AIR MACHINE	1
21	8437D002	ETL DECAL, AIR MACHINES	1
22	8532-25	AIR HOSE ASSY, 1/4" X 25'	2
23	8533-8	TIRE INFLATOR W/ GAUGE	1
24	8549	FLEX STRAIN RELIEF	2
25	8596	NUT, 5/16-18 HEX	4
26	8597	5/16 WASHER	4
27	8598	5/16 LOCK WASHER	4
28	8647	WATER SPOUT, 1/4" NPT	1
29	8659-3W	WELDMENT, AIR MACHINE, JEA	1
30	8659-75-W-PLT	LOCK BAR PLATED	1
31	8670KIT-2W	HARDWARE PACK, PED AIR/WATER MACHINE	1
32	8673	TIMER ASSEMBLY-SSAC	1
33	8673-9	NEON LIGHT ASSEMBLY	1
34	8732	NAMEPLATE SERIAL TAG, UL	1



E	7662	REMOVE PARTS 5900D1, 5900D4 & 8176, ADD PARTS AS LISTED	012816	JF
D	7596	ADD 8180 DECAL BELOW TERMINAL STRIP	102315	JF
C	7215	REMOVED (2) 8659-13, (4) 5627D2 AND (4) 8157	10-29-13	CK
B	6947	REMOVED 8659-75 AND ADDED 8659-75-W-PLT	5-10-12	CK
A	6792	REMOVED ALL 8687 AND 8687-1	2-6-12	CK
REV	NO.	DESCRIPTION	DATE	BY

PAGE 1 OF 2	
TITLE AIR/WATER MACHINE, PED MOUNT MODEL, GAST TWIN	
UNSPECIFIED TOLERANCES	MATERIAL
1 PL ±.030	SCALE
2 PL ±.010	DRAWN BY JOHN F.
3 PL ±.003	DATE 5/3/2011
ANGLE ±1.0°	 CEDAR RAPIDS, IOWA PART NO. 8670-2WGA REV. E

THIS DOCUMENT SHALL NOT BE REPRODUCED NOR SHALL THE INFORMATION THEREIN BE USED BY OR DISCLOSED TO OTHERS EXCEPT AS AUTHORIZED BY J.E. ADAMS INDUSTRIES

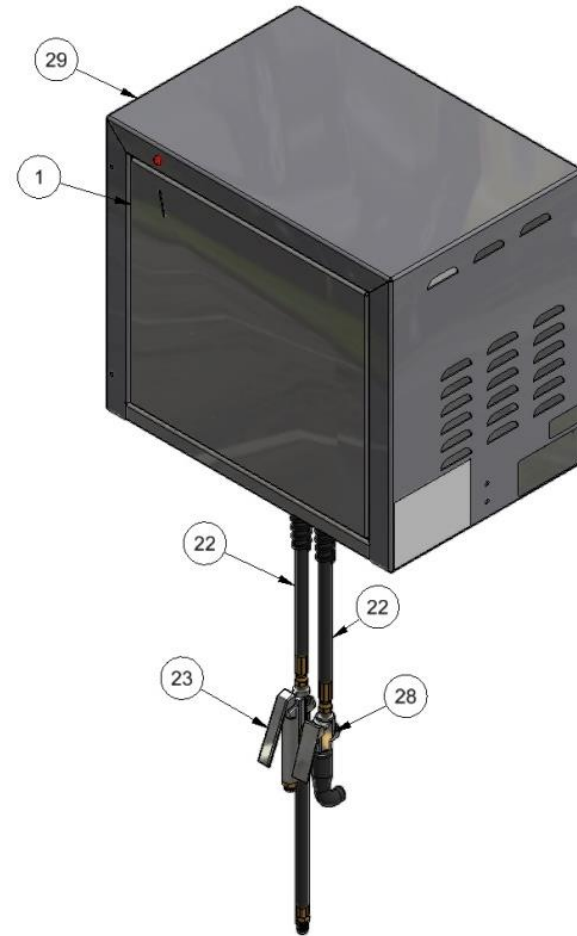
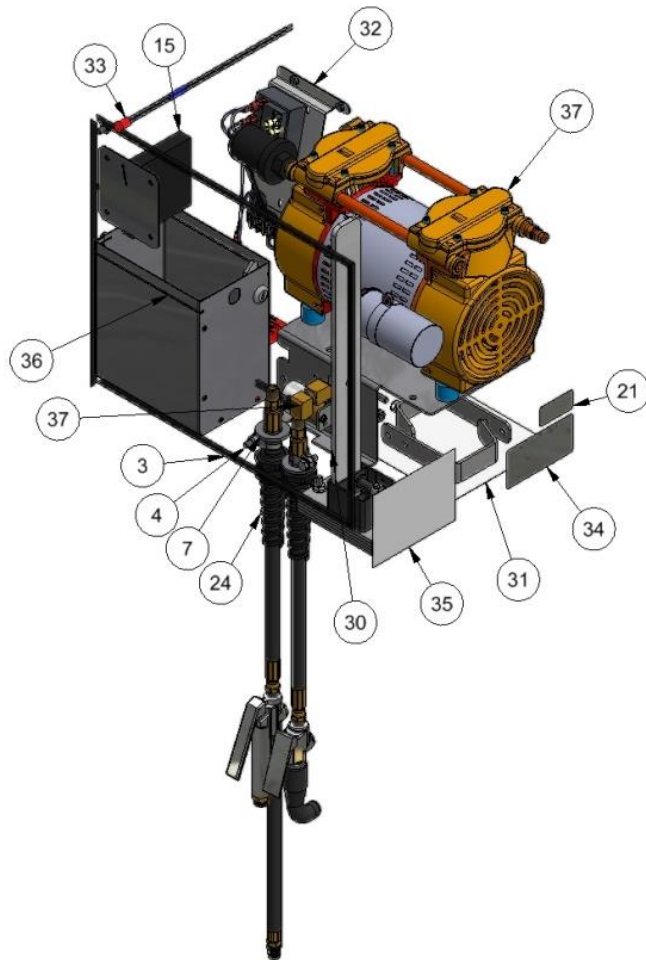

TITLE		AIR/WATER MACHINE, PED MOUNT MODEL, GAST TWIN	
UNSPECIFIED TOLERANCES	MATERIAL	 CEDAR RAPIDS, IOWA	
1 PL ±.030	SCALE		
2 PL ±.010	DRAWN BY	JOHN F.	
3 PL ±.003	DATE	5/3/2011	
ANGLE ±1.0°	PART NO.	8670-2WGA	
	REV.	E	

REV	NO.	DESCRIPTION	DATE	BY
THIS DOCUMENT SHALL NOT BE REPRODUCED NOR SHALL THE INFORMATION THEREIN BE USED BY OR DISCLOSED TO OTHERS EXCEPT AS AUTHORIZED BY J.E. ADAMS INDUSTRIES				

PART NO. **8671-2GA**

BILL OF MATERIALS			
ITEM	PART NUMBER	DESCRIPTION	QTY
35	8754	DECAL, DANGER, TRI-LING	1
36	8773-3	AIR MACHINE COIN BOX	1
37	9500-56	WIRING HARNESS, BILL VAL	1
38	9862-1A	ASSEMBLY, GAST COMPRESSOR	1
39	S8671 SERIES SSAC	WIRING DIAGRAM	X
45	8180 	WARNING, WIRE TEMP RATING	1

BILL OF MATERIALS			
ITEM	PART NUMBER	DESCRIPTION	QTY
1	10011V-3W	VALIDATOR DOOR WELDMENT, AIR MACHINE	1
2	1079-3	GASKET, RUBBER SEAL (DOOR)	60"
3	5600D2	5/16-18 x .75 CARR BOLT	2
4	5601D4	1/4-20 x 3/4 HHCS-SS	1
5	5601D8	1/4-20 x 3/8 HHCS-ZINC PLATED	5
6	5603D2	1/4 Std NC Nylock Nut	1
7	5606D21	WASHER, FLAT, 3/4 SAE, ID 13/16	1
8	5611D2	NUT, 10-24 UNC KEPP- ZINC	4
9	5684D2	1/2" DIA. HOSE CLAMP	1
10	5900D4	CONNECTOR, FEMALE, RED INSL .250"	1
11	6408	CARDBOARD INSERT	2
12	6409	CARDBOARD BOX	1
13	8081	CABLE TIE MOUNTS	3
14	8084	CABLE TIE, NYLON 5-3/4	5
15	8124B001	COIN ACCEPTOR, IMONEX	1
16	8130-6	MEI MARS, 110V BILL VALIDATOR	1
17	8155A	LOCK ASSY-W/MEDECO CAM LOCK	1
18	8157	NUT, #6-32 KEPP NUT STAINLESS	8
19	8176	DECAL, LINE-NEUTRAL-GROUND	1
20	8183	DECAL, "DISCONNECT POWER"	1
21	8430V-1AKIT	DECAL KIT, AIR MACHINE	1
22	8437D002	ETL DECAL, AIR MACHINES	1
23	8532-25	AIR HOSE ASSY, 1/4" X 25'	1
24	8533-8	TIRE INFLATOR W/ GAUGE	1
25	8549	FLEX STRAIN RELIEF	1
26	8596	NUT, 5/16-18 HEX	4
27	8597	5/16 WASHER	4
28	8598	5/16 LOCK WASHER	4
29	8659-3W	WELDMENT, AIR MACHINE, JEA	1
30	8659-75-W-PLT	LOCK BAR PLATED	1
31	8670KIT-2	HARDWARE PACK, PED AIR MACHINE	1
32	8673	TIMER ASSEMBLY-SSAC	1
33	8673-9	NEON LIGHT, RED, 18IN. BLK	1
34	8732	NAMEPLATE SERIAL TAG, UL	1



PAGE 1 OF 2

REV	NO.	DESCRIPTION	DATE	BY
C	7597	ADD 8180 DECAL BELOW OR NEAR TERMINAL STRIP	102615	JF
B	7215	REMOVED (2) 8659-13, (4) 5627D2 AND (4) 8157	10-31-13	CK
A	6947	REMOVED 8659-75 AND ADDED 8659-75-W-PLT	5-10-12	CK

THIS DOCUMENT SHALL NOT BE REPRODUCED NOR SHALL THE INFORMATION THEREIN BE USED BY OR DISCLOSED TO OTHERS EXCEPT AS AUTHORIZED BY J.E. ADAMS INDUSTRIES

TITLE					
AIR MACHINE W/VAL, PED MOUNT MODEL, GAST TWIN					
UNSPECIFIED TOLERANCES	MATERIAL	CEDAR RAPIDS, IOWA			
SCALE					
1 PL ±.030				DRAWN BY	JOHN F.
2 PL ±.010				DATE	1/24/2012
3 PL ±.003	PART NO.	8671-2GA	REV. C		
ANGLE ±1.0°					

PART NO. 8671-2GA

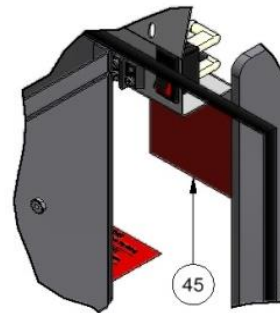
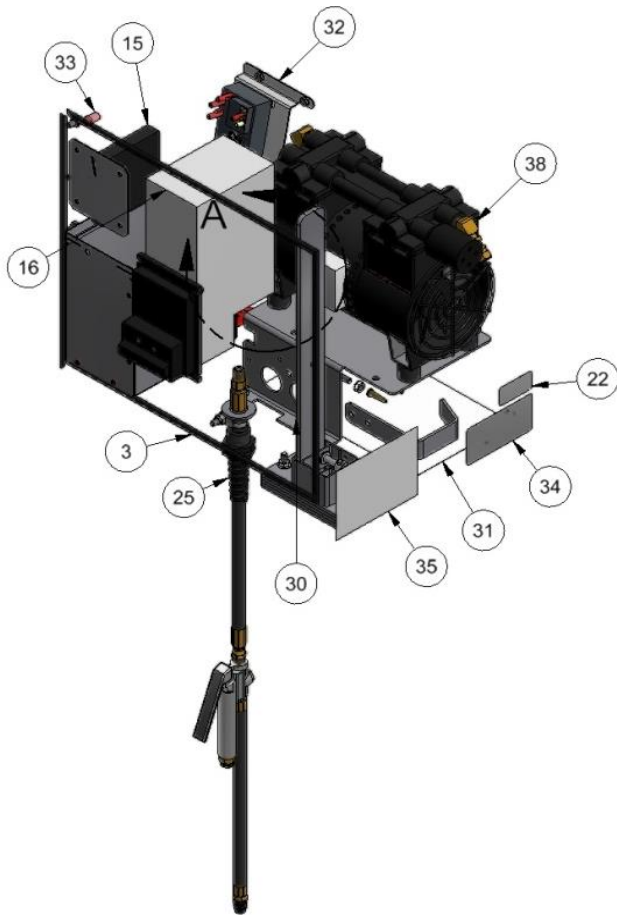

DETAIL A
SCALE 0.28 : 1

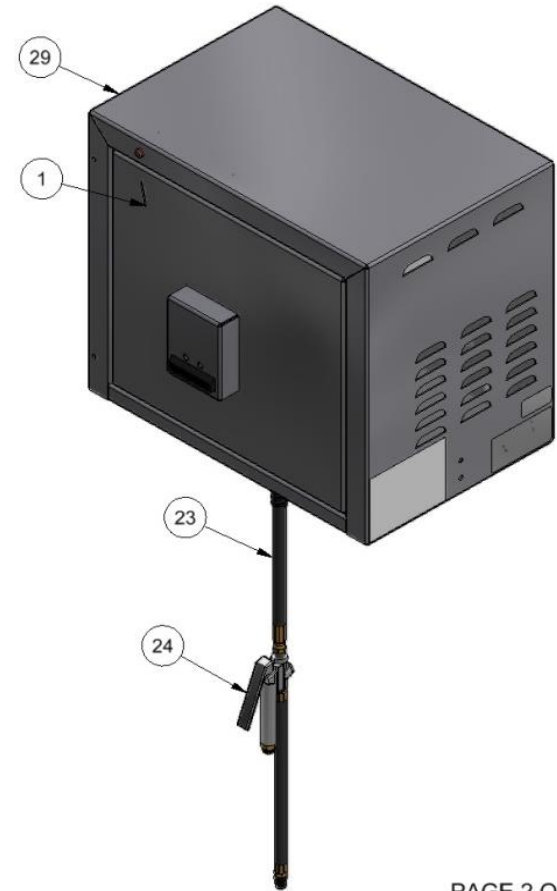

PAGE 2 OF 2

TITLE		AIR MACHINE W/VAL, PED MOUNT MODEL, GAST TWIN	
UNSPECIFIED TOLERANCES	MATERIAL	 CEDAR RAPIDS, IOWA	
1 PL ±.030	SCALE		
2 PL ±.010	DRAWN BY	JOHN F.	
3 PL ±.003	DATE	1/24/2012	
ANGLE ±1.0°	PART NO.	8671-2GA	
	REV.	C	

REV	NO.	DESCRIPTION	DATE	BY
THIS DOCUMENT SHALL NOT BE REPRODUCED NOR SHALL THE INFORMATION THEREIN BE USED BY OR DISCLOSED TO OTHERS EXCEPT AS AUTHORIZED BY J.E. ADAMS INDUSTRIES				

PART NO. **8670-2VGA**

BILL OF MATERIALS			
ITEM	PART NUMBER	DESCRIPTION	QTY
35	8754	DECAL, DANGER, TRI-LING	1
36	9862-1A	ASSEMBLY, GAST COMPRESSOR	1
37	S8670 SERIES SSAC	WIRING DIAGRAM	X
46	8180 	WARNING, WIRE TEMP RATING	1



BILL OF MATERIALS			
ITEM	PART NUMBER	DESCRIPTION	QTY
1	10011-3WV	DOOR WELDMENT, VR, AIR MACHINE	1
2	1009	COIN FUNNEL, VR VENDOR	1
3	1079-3	GASKET, RUBBER SEAL (DOOR)	60"
4	5600D2	5/16-18 x .75 CARR BOLT	2
5	5601D4	1/4-20 x 3/4 HHCS-SS	1
6	5601D8	1/4-20 x 3/8 HHCS-ZINC PLATED	5
7	5603D2	1/4 Std NC Nylock Nut	1
8	5606D21	WASHER, FLAT, 3/4 SAE, ID 13/16	1
9	5611D2	NUT, 10-24 UNC KEPP- ZINC	4
10	5684D2	1/2" DIA. HOSE CLAMP	1
11	5900D4	CONNECTOR, FEMALE, RED INSL .250"	1
12	6408	CARDBOARD INSERT	2
13	6409	CARDBOARD BOX	1
14	8081	CABLE TIE MOUNTS	3
15	8084	CABLE TIE, NYLON 5-3/4	5
16	8124B001	COIN ACCEPTOR, IMONEX	1
17	8155A	LOCK ASSY-W/MEDECO CAM LOCK	1
18	8157	NUT, #6-32 KEPP NUT STAINLESS	4
19	8176	DECAL, LINE-NEUTRAL-GROUND	1
20	8183	DECAL, "DISCONNECT POWER"	1
21	8437D002	ETL DECAL, AIR MACHINES	1
22	8532-25	AIR HOSE ASSY, 1/4" X 25'	1
23	8533-8	TIRE INFLATOR W/ GAUGE	1
24	8549	FLEX STRAIN RELIEF	1
25	8596	NUT, 5/16-18 HEX	4
26	8597	5/16 WASHER	4
27	8598	5/16 LOCK WASHER	4
28	8659-3WV	WELDMENT, VR AIR MACHINE, JEA	1
29	8659-75-W-PLT	LOCK BAR PLATED	1
30	8670KIT	HARDWARE PACK, COIN MACH AIR	1
31	8670V-KIT	DECAL, VAULT READY AIR MACHINE	1
32	8673	TIMER ASSEMBLY-SSAC	1
33	8673-9	NEON LIGHT, RED, 18IN. BLK	1
34	8732	NAMEPLATE SERIAL TAG, UL	1

E	7596	ADD 8180 DECAL BELOW TERMINAL STRIP	102315	JF
D	7215	REMOVED (2) 8659-13, (4) 5627D2 AND (4) 8157	10-29-13	CK
C	7041	REMOVED 8430-1AKIT AND ADDED 8670V-KIT	11-7-12	CK
B	6947	REMOVED 8659-75 AND ADDED 8659-75-W-PLT	5-9-12	CK
A	6798	REMOVED ALL 8687 AND 8687-1	2-7-12	CK
REV	NO.	DESCRIPTION	DATE	BY

PAGE 1 OF 2

TITLE **AIR MACHINE, PED MOUNT VR MODEL, GAST TWIN**

UNSPECIFIED TOLERANCES	MATERIAL
1 PL ±.030	SCALE
2 PL ±.010	DRAWN BY JOHN F.
3 PL ±.003	DATE 4/21/2011
ANGLE ±1.0°	



PART NO. 8670-2VGA	REV. E
---------------------------	---------------

THIS DOCUMENT SHALL NOT BE REPRODUCED NOR SHALL THE INFORMATION THEREIN BE USED BY OR DISCLOSED TO OTHERS EXCEPT AS AUTHORIZED BY J.E. ADAMS INDUSTRIES

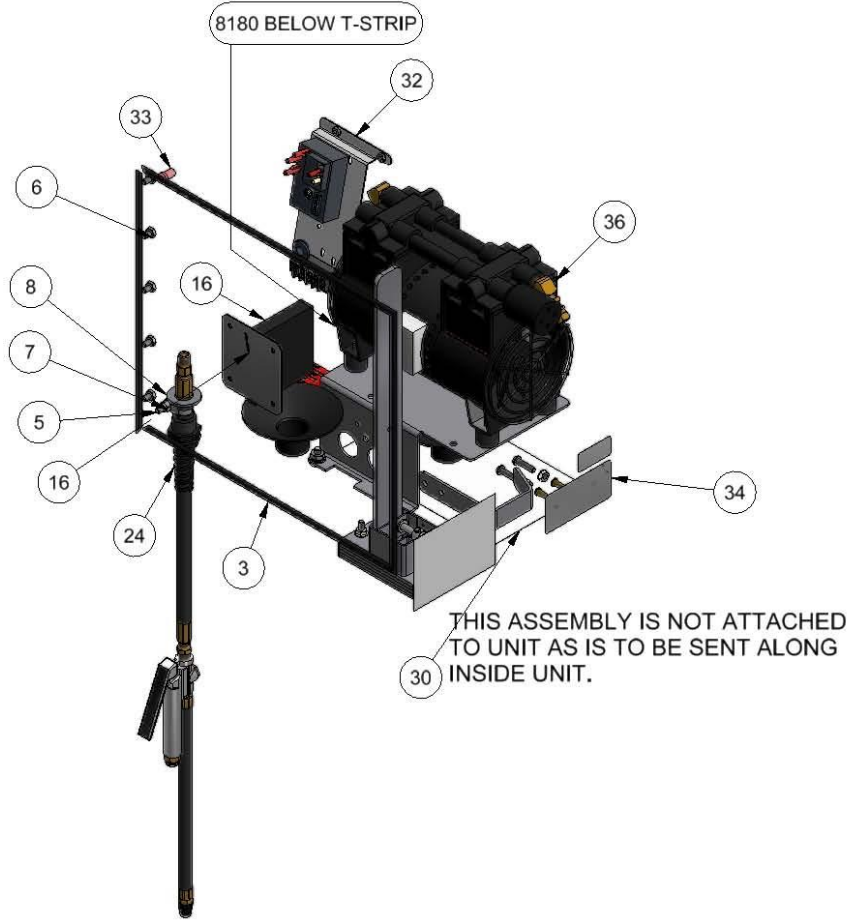

TITLE		CEDAR RAPIDS, IOWA	
AIR MACHINE, PED MOUNT VR MODEL, GAST TWIN			
UNSPECIFIED TOLERANCES	MATERIAL		
1 PL ±.030	SCALE	DRAWN BY JOHN F.	PART NO. 8670-2VGA
2 PL ±.010	DATE 4/21/2011		
3 PL ±.003			
ANGLE ±1.0°			

REV	NO.	DESCRIPTION	DATE	BY
THIS DOCUMENT SHALL NOT BE REPRODUCED NOR SHALL THE INFORMATION THEREIN BE USED BY OR DISCLOSED TO OTHERS EXCEPT AS AUTHORIZED BY J.E. ADAMS INDUSTRIES				

8673

AIR STANDARD

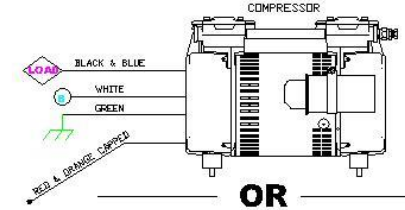
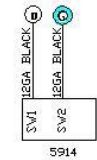
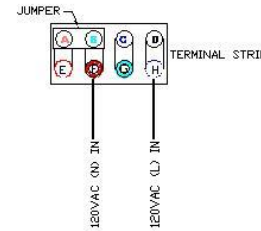
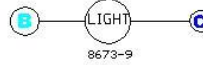
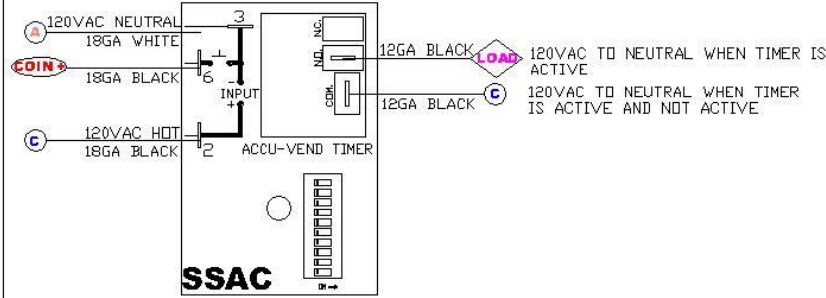

SOLENOID FOR COMPRESSOR-LESS UNITS ONLY

OPTIONAL ACCEPTORS SSAC

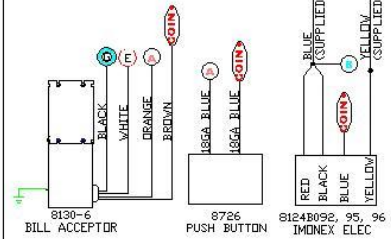

SOLENOID WATER OPTION

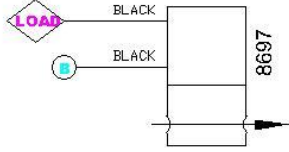

OPTIONAL TIMER

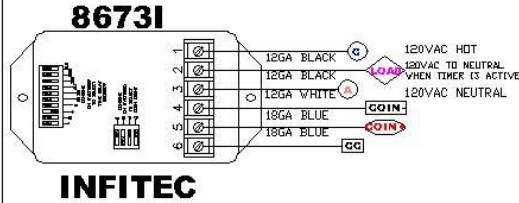

OPTIONAL ACCEPTORS INFITEC

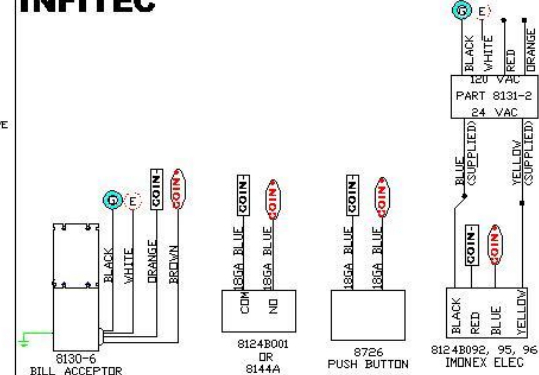

IMPORTANT INFORMATION

!! IMPORTANT !!
 FIELD WIRING MUST COMPLY WITH LOCAL AND NATIONAL ELECTRICAL CODES.
10AMP SERVICE IS REQUIRED FOR TWIN GAST UNITS

OPTIONAL COUNTERS



THIS DOCUMENT SHALL NOT BE REPRODUCED NOR SHALL THE INFORMATION THEREIN BE USED BY OR DISCLOSED TO OTHERS EXCEPT AS AUTHORIZED BY J.E. ADAMS INDUSTRIES!		 CEDAR RAPIDS, IOWA	UNSPECIFIED TOLERANCES	TITLE	AIR MACHINE 120V			
1 PL ±.030	2 PL ±.010		3 PL ±.003	ANGLE 1:1.0	DRAWN BY	DATE	SCALE	REL FOR PRG.
REV	NO.	DESCRIPTION	DATE	BY	CHAD K.	3-3-16	NONE	AIR MACHINE 120V